



# Antimicrobial

## Institutional Commercial



### DETAILS

**AM820STS**

Antimicrobial, Extra Heavy Duty, open front with cover for elongated bowl. Stainless steel check hinge.

**AMFR820STS**

Antimicrobial, fire retardant, Extra Heavy Duty, open front with cover for elongated bowl. Stainless steel check hinge.

**Standard Features:**

- Corrosion free steel hinge
- Integrally molded permanent and sanitary color keyed bumpers
- Corrosion free hardware
- Withstands cleansers, strong chemicals
- Easy clean
- Finger lift

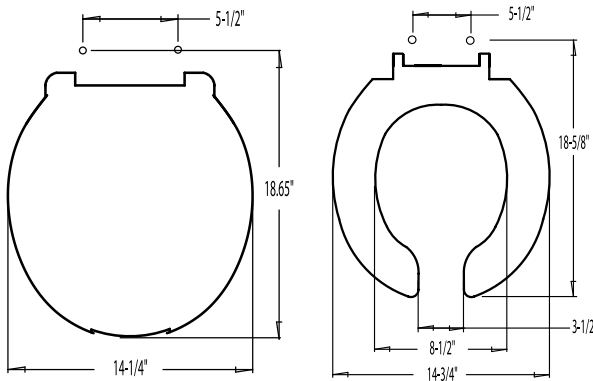

### SPECIFICATIONS

Seats shall be Centoco No. \_\_\_\_\_  
Seat and cover shall be injection molded of polypropylene with integrally molded permanent bumpers.

Color to be \_\_\_\_\_.